

NEW

High Current Power Connector for Internal Automotive Connection, Heat Resistant up to 125°C

HVH-280 Series



● High Current Terminal

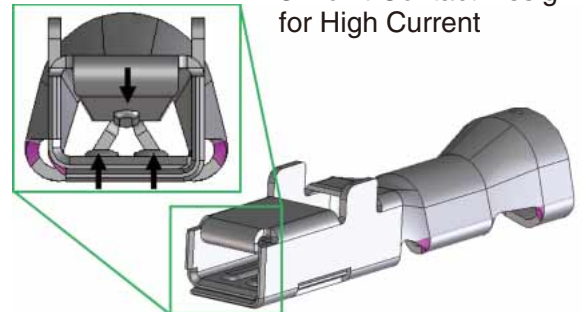

Fig.1

■ Features

- 1. Rated Current : 30A, Rated Voltage : 600V AC/DC**
- 2. High Heat Resistance**
Suitable for use in 125°C environments.
- 3. High Reliability 3-Point Contact Design**
High contact pressure design enables high current capacity.
- 4. High Vibration Resistance**
The cable sheath is firmly secured to reduce cable runout during vibration.
- 5. Lock Designed for Easy Operation**
Stroke depth and long lock arm allow workers to operate the lock with ease.
- 6. Clear Tactile Click and Stable Connection**
Clear tactile click during mating and firm lock supports reliable mating operation.
- 7. Crimp Terminal Insertion Ensured**
Retainer prevents incomplete insertion of crimp terminals.
- 8. Prevents Mis-Insertion**
Designed to prevent reversed insertion of terminals and reversed connector insertion during mating.

● 600V Rated Voltage

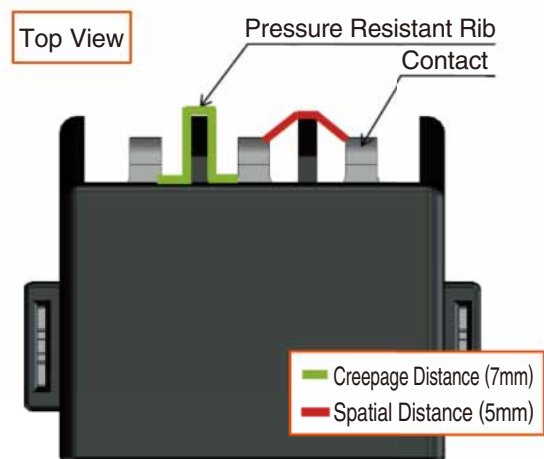

Fig.2

● Incomplete Insertion Prevention and High Vibration Resistance

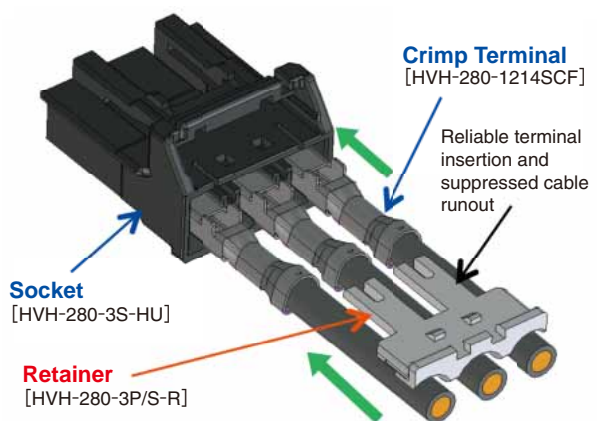

Fig.3

Product Specifications

Ratings	Rated Current	30A (Note 1)	Operating Temperature	-40°C to +125°C
			Storage Temperature Range	-10°C to +60°C (Note 2)
	Rated Voltage	600V AC/DC	Storage Humidity Range	Relative humidity 85% or less (No condensation)

Items	Specifications	Conditions
1. Contact Resistance	100MΩ Min	Measured at 1000V DC
2. Withstanding Voltage	There shall be no dielectric breakdown or flashover.	2200V AC applied for 1minute.
3. Voltage Drop	5mΩ Max	Measured at A (Cable cross-sectional area×5) DC
4. Connector Insertion Force	45N Max. No damage, strain or deformation to components.	Inserted at a constant speed of 50mm/min Max.
5. Connector Unmating Force	75N Max. No damage, strain or deformation to components.	Removed at a constant speed of 50mm/min Max.
6. Connector Retention Force	110N Min.	Removed at a constant speed of 50mm/min Max.
7. Vibration/ Mechanical Shock	Voltage Drop : 5mΩ Max. Contact Resistance : 100MΩ Min. No electrical discontinuity of 1μs or more. No damage, strain or deformation to components.	[Vibration] Random vibration frequency 5 to 1000Hz (Acceleration/1.81grms) 8 hour test in each of the three directions under the above conditions [Shock] Acceleration of 35G, 10 times in both directions of the 3 axes
8. Thermal Shock	Voltage Drop : 5mΩ Max. Contact Resistance : 100MΩ Min. No electrical discontinuity of 1μs or more. Withstanding Voltage:No dielectric breakdown or flashover. No damage, strain or deformation to components.	Temperature -40°C → Room temperature → 125°C → Room temperature Time : 30 → 5 → 30 → 5 minutes for 100 cycles
9. Temperature Cycle	Retention force between contact and connector : 50N. Min. Voltage Drop : 5mΩ Max. Contact Resistance : 100MΩ Min. Withstanding Voltage : No dielectric breakdown or flashover. No damage, strain or deformation to components.	Left for 40 cycles at a temperature of -40 to 125°C, and relative humidity of 80 to 100%
10. High Temperature Storage	Voltage Drop : 5mΩ Max. Contact Resistance : 100MΩ Min. Withstanding Voltage : No dielectric breakdown or flashover. No damage, strain or deformation to components.	Left at a temperature of 125°C for 1008 hours.

Note 1 : The rating current depends on operating temperature and cable used. Please contact a Hirose Sales Office for inquiries.

Note 2 : This storage temperature is for long-term storage of unused products.

Materials/Finish

Component	Part	Material	Finish	UL Standard
Header	Housing	PBT Resin	Black	UL94V-0
	Crimp Terminal	Copper Alloy	Tin Plating	—
	Retainer	PBT Resin	Dark Gray	UL94V-0
Socket	Housing	PA Resin	Black	UL94V-0
	Terminal	Copper Alloy	Tin Plating	—
	Solder Tabs	Phosphor Bronze	Tin Plating	—

Product Number Structure

Refer to the chart below when determining the product specifications from the product number. Please select from the product numbers listed in this catalog when placing orders.

● Connector

HVH-280 – 3 P 6.5 DS

①
②
③
④
⑤

● Terminal

HVH-280 – 1214 SCF

⑥
⑦

① Series Name : HVH-280
② No. of Pos : 3
③ Connector Type P : Header S : Socket
④ Contact Pitch : 6.5mm
⑤ Termination Form DS : Right Angle DIP HU : Housing
⑥ Applicable Cable Size 1214 : 12 to 14 AWG
⑦ Form Type/Packaging SCF Socket Contact/Reel

Product Configurations

Header

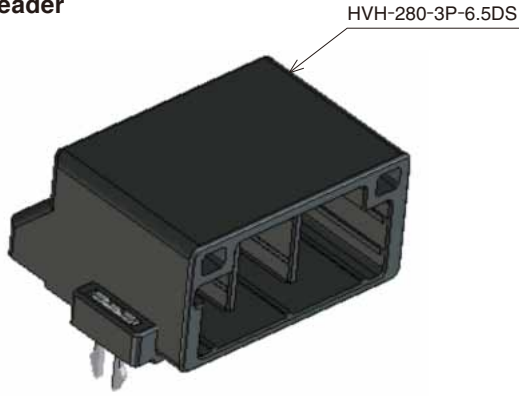

Socket

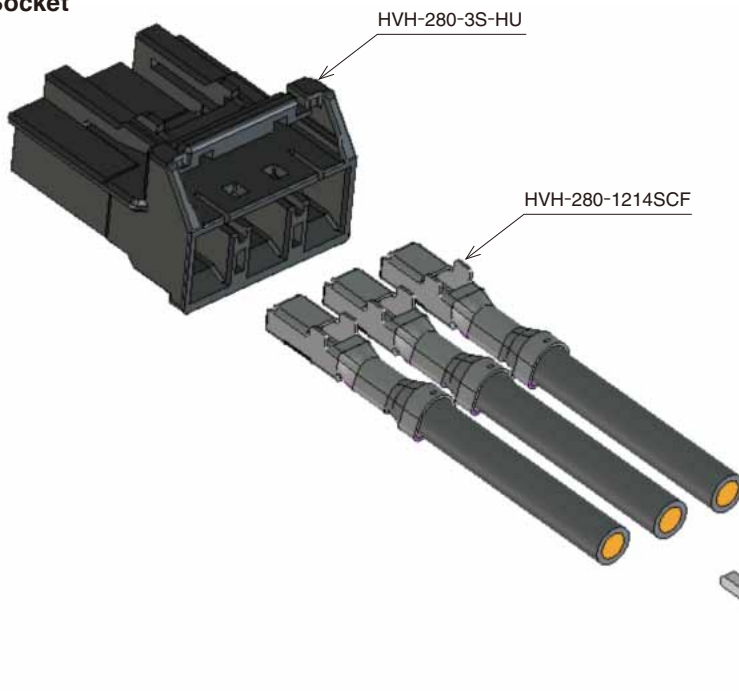

Assembled Socket Connector

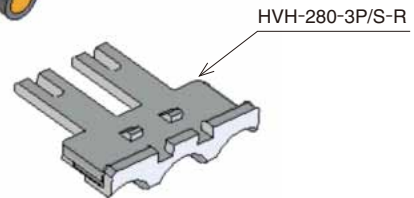
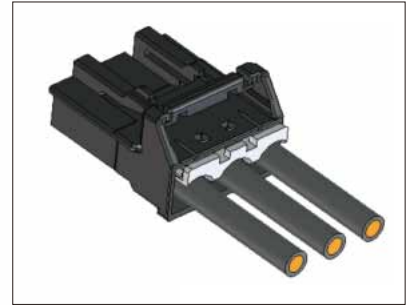

HVH-280 Series Mating Table

Header		Socket	
HVH-280 3pos. Header (Board Side)	Configuration Product Name	HVH-280 3pos. Socket	Configuration Product Name
	HVH-280-3P-6.5DS		HVH-280-3S-HU
			HVH-280-3P/S-R
			HVH-280-1214SCF

Right Angle Header

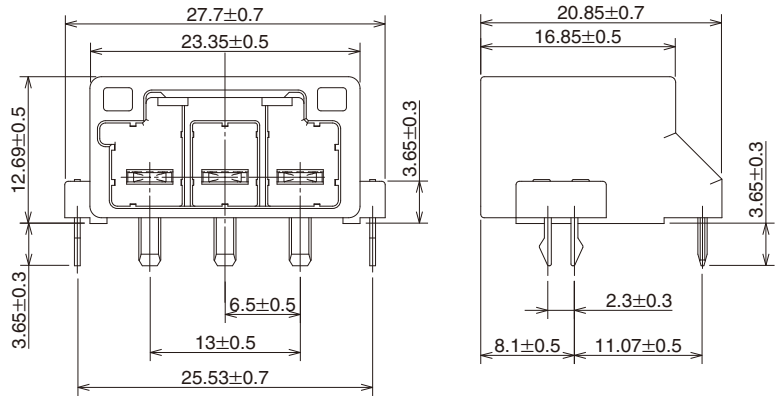

Part No.	HRS No.	No. of Pos.	Number of tray packages	Finish
HVH-280-3P-6.5DS	778-0700-0	3	560	Tin Plating

Note : Tray packages must be ordered in multiples of 560.

Socket Housing

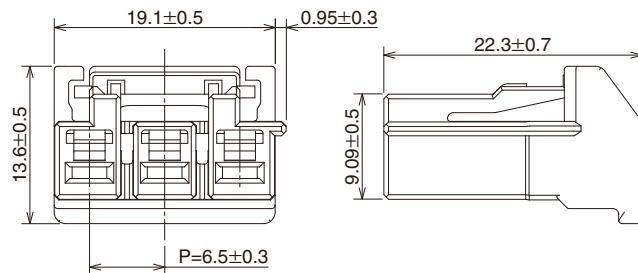

Part No.	HRS No.	No. of Pos.
HVH-280-3S-HU	778-0701-0	3

Note : The product is sold in packs (100 pieces per pack) so please order based on number of packs.

Socket Retainer

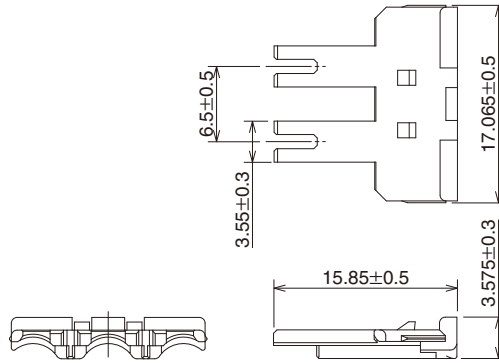

Part No.	HRS No.	No. of Pos.
HVH-280-3P/S-R	778-0702-0	3

Note : The product is sold in packs (100 pieces per pack) so please order based on number of sets.

Socket Crimp Terminal

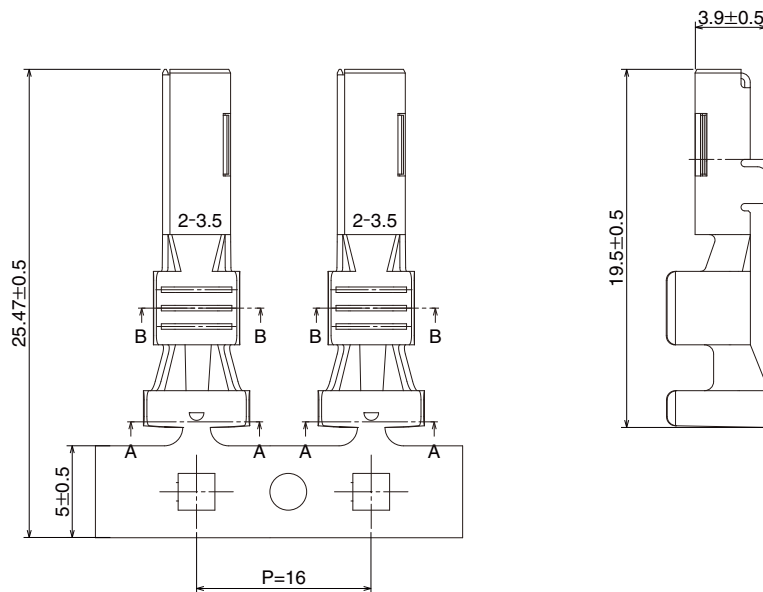

Part No.	HRS No.	Type	Amount	Finish
HVH-280-1214SCF	778-0502-0	Reel Terminal	1,700 pcs/reel	Tin Plating

Note 1 : The applicable cable's conductor is a tin plated soft copper wire.

Note 2 : Please contact a Hirose representative regarding whether crimp tools from other manufacturers can be used.

Note 3 : The applicable cable size is 12 to 14 AWG (2 to 3.5mm²).

Applicable Crimp Too

Type	Part No.	HRS No.	Applicable Contact
Applicator	AP105-HVH-280-1214S	901-5244-0	HVH-280-1214SCF

Note 1 : Please contact a Hirose representative regarding whether crimp tools from other manufacturers can be used.

Note 2 : Crimping work shall be conducted in accordance with the "Crimping Standard" and "Crimping Conditions Table".

◆ How to Extract the Terminal

- Terminal Extraction Tools : Precise screwdriver (flathead screwdriver)
- Applicable crimp terminals : HVH-280-1214SCF
- Operation Method

● Repair Method

To repair, press the mold lance with the terminal extraction tool in the direction shown in the diagram below. While pressing extract the terminal. Make sure not to deform the terminal lock or contact part.

Caution : Do not push the terminal locking feature or contact. It may lead to deformation or damage to the housing and other parts. When damaged, please replace it with a new one.

HVH-280-1214SCF

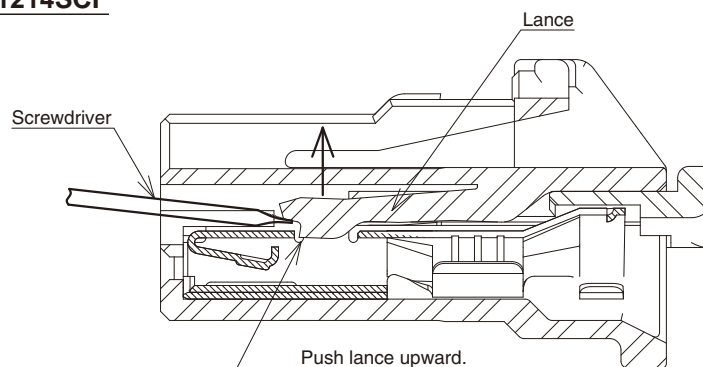

◆ Usage Precautions

1. Pulling out the connector with force may result in damage. If it is difficult to pull out, lightly push it once and then operate the lock to pull it out.
2. When inserting or extracting the terminal, always disconnect from the power source first.
3. Do not touch the terminals while the power is on since it is very dangerous.
4. Contact a sales representative for harness instructions and handling manuals.
5. Do not perform insertion or extraction with a live wire. (Live wire insertion/extraction refers to inserting/extracting while electricity is running)

◆ Usage Environment

Please consult with your Hirose Electric sales representative if your system environmental conditions repeat high and low temperatures.

USA:

HIROSE ELECTRIC (U.S.A.), INC. HEADQUARTERS CHICAGO OFFICE
2300 Warrenville Road, Suite 150,
Downers Grove, IL 60515
Phone : +1-630-282-6700
<http://www.hirose.com/us/>

USA:

HIROSE ELECTRIC (U.S.A.), INC. SAN JOSE OFFICE
2841 Junction Ave, Suite 200
San Jose, CA. 95134
Phone : +1-408-253-9640
Fax : +1-408-253-9641
<http://www.hirose.com/us/>

USA:

HIROSE ELECTRIC (U.S.A.), INC. DETROIT OFFICE (AUTOMOTIVE)
17197 N. Laurel Park Drive, Suite 253,
Livonia, MI 48152
Phone : +1-734-542-9963
Fax : +1-734-542-9964
<http://www.hirose.com/us/>

USA:

HIROSE ELECTRIC (U.S.A.), INC. BOSTON OFFICE
300 Brickstone Square Suite 201,
Andover, MA 01810
Phone : +1-978-662-5255

THE NETHERLANDS:

HIROSE ELECTRIC EUROPE B.V.
Hogehillweg #8 1101 CC Amsterdam Z-0
Phone : +31-20-6557460
Fax : +31-20-6557469
<http://www.hirose.com/eu/>

GERMANY:

HIROSE ELECTRIC EUROPE B.V. GERMAN BRANCH
Schoenbergstr. 20, 73760 ostfildern
Phone : +49-711-456002-1
Fax : +49-711-456002-299
<http://www.hirose.com/eu/>

GERMANY:

HIROSE ELECTRIC EUROPE B.V. NUREMBERG OFFICE
Neumeyerstrasse 22-26, 90411 Nurnberg
Phone : +49-911 32 68 89 63
Fax : +49-911 32 68 89 69
<http://www.hirose.com/eu/>

GERMANY:

HIROSE ELECTRIC EUROPE B.V. HANOVER OFFICE
Bayernstr. 3, Haus C 30855 Langenhagen, Germany
Phone : +49-511 97 82 61 30
Fax : +49-511 97 82 61 35
<http://www.hirose.com/eu/>

FRANCE:

HIROSE ELECTRIC EUROPE B.V. PARIS OFFICE
130 Avenue Joseph Kessel, Bat E, 78960
Voisins le Bretonneux, France
Phone : +33-1-85764886
Fax : +33-1-85764823
<http://www.hirose.com/eu/>

UNITED KINGDOM:

HIROSE ELECTRIC EUROPE BV (UK BRANCH)
4 Newton Court, Kelvin Drive, Knowlhill,
Milton Keynes, MK5 8NH
Phone : +44-1908 202050
Fax : +44-1908 202058
<http://www.hirose.com/eu/>

CHINA:

HIROSE ELECTRIC (CHINA) CO., LTD. (SHANGHAI, HEADQUARTERS)
18, Enterprise Center Tower 2, 209# Gong He
Road, Jing'an District, Shanghai, CHINA 200070
Phone : +86-21-6391-3355
Fax : +86-21-6391-3335
<http://www.hirose.com/cn/>

CHINA:

HIROSE ELECTRIC (CHINA) CO., LTD. BEIJING BRANCH
A1001, Ocean International Center, Building 56# East 4th
Ring Middle Road, ChaoYang District, Beijing, 100025
Phone : +86-10-5165-9332
Fax : +86-10-5908-1381
<http://www.hirose.com/cn/>

CHINA:

HIROSE ELECTRIC (CHINA) CO., LTD. SHENZHEN BRANCH
Room 09-13, 19/F, Office Tower Shun Hing Square, Di Wang Commercial Centre,
5002 Shen Nan Dong Road, Shenzhen City, Guangdong Province, 518008
Phone : +86-755-8207-0851
Fax : +86-755-8207-0873
<http://www.hirose.com/cn/>

HONG KONG:

HIROSE ELECTRIC HONGKONG TRADING CO., LTD.
Room 1001, West Wing, Tsim Sha Tsui Centre, 66
Mody Road, Tsim Sha Tsui East, Kowloon, Hong Kong
Phone : +852-2803-5338
Fax : +852-2591-6560
<http://www.hirose.com/hk/>

TAIWAN:

HIROSE ELECTRIC TAIWAN CO., LTD.
103 8F, No.87, Zhengzhou Rd., Taipei
Phone : +886-2-2555-7377
Fax : +886-2-2555-7355
<http://www.hirose.com/tw/>

KOREA:

HIROSE KOREA CO., LTD.
143, Gongdan 1-daero, Siheung-si,
Gyeonggi-do, 15084, Korea
Phone : +82-31-496-7000
Fax : +82-31-496-7100
<http://www.hirose.co.kr/>

SINGAPORE:

HIROSE ELECTRIC SINGAPORE PTE. LTD.
03, Anson Road, #20-01, Springleaf Tower,
Singapore 079909
Phone : +65-6324-6113
Fax : +65-6324-6123
<http://www.hirose.com/sg/>

INDIA:

HIROSE ELECTRIC SINGAPORE PTE. LTD. DELHI LIAISON OFFICE
Office NO.552, Regus-Green Boulevard, Level5, Tower C,
Sec62, Plot B-9A, Block B, Noida, 201301, Uttar Pradesh, India
Phone : +91-12-660-8018
Fax : +91-120-4804949
<http://www.hirose.com/sg/>

INDIA:

HIROSE ELECTRIC SINGAPORE PTE. LTD. BANGALORE LIAISON OFFICE
Unit No-403, 4th Floor, No-84, Barton Centre, Mahatma
Gandhi (MG) Road, Bangalore 560 001, Karnataka, India
Phone : +91-80-4120 1907
Fax : +91-80-4120 9908
<http://www.hirose.com/sg/>

MALAYSIA:

PENANG REPRESENTATIVE OFFICE
73-3-1, Ideal@The One, Jalan Mahsuri, Bayan
Lepas Penang, 11950, Malaysia
Phone : +604-648-5536
<http://www.hirose.com/sg/>

THAILAND:

BANGKOK OFFICE (REPRESENTATIVE OFFICE)
Unit 4703, 47th FL., 1 Empire Tower, South Sathorn
Road, Yannawa, Sathorn, Bangkok 10120 Thailand
Phone : +66-2-686-1255
Fax : +66-2-686-3433
<http://www.hirose.com/sg/>



HIROSE ELECTRIC CO., LTD.

2-6-3, Nakagawa Chuoh, Tsuzuki-Ku, Yokohama-Shi 224-8540, JAPAN
TEL: +81-45-620-3526 Fax: +81-45-591-3726
<http://www.hirose.com>
<http://www.hirose-connectors.com>