

High Speed Transmission, 0.8 mm Pitch Connectors for PCB Connections

FX18 Series

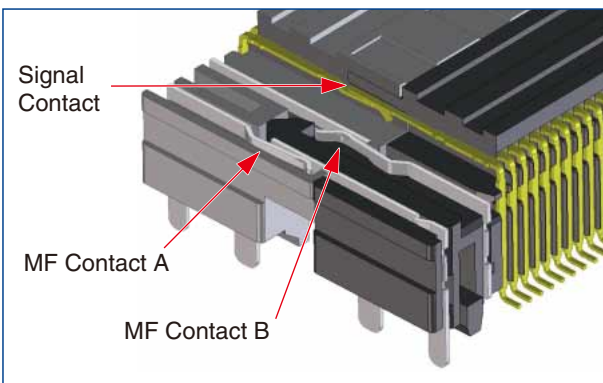

■ Features

- **0.8 mm pitch**
- **Connection type: Coplanar /right angle / parallel (height: 10 to 45 mm)**
- **No of pos.: 40, 60, 80, 100, 120, 140**
- **MF (multi-functional) contact**
The FX18 series utilizes guideposts on both sides of the connector. These guide posts double as multi-functional contacts as well as an aligning structure.
 - 1) Enhanced ground connections between PCB's
 - 2) Capable of being used as power source lines (3 A/line)
 - 3) A sequenced 3-level structure that contains signal contacts
- **Effective mating length of 2 mm (Signal contact)**
This connector utilizes a 2.0 mm effective mating length for its signal contacts and provides a sufficient amount of margin for its mating sequence. (MF contact A: 2.5 mm/ MF contact B: 1.5 mm)
- **Resistant to excess mating force**
The structure is equipped with dip contacts that help prevent damage caused by excessive mating forces and provides stability to both sides of the connector.
- **Simplified mating with large guides**
Generous lead-in shape simplifies the mating operation. (lead in opening amount: ± 1 mm). The guides also prevent inverse mating.

■ High speed transmission characteristics

- **ICR (Insertion-loss-to-Crosstalk-Ratio)**
Enough margin with regulated ICR data of IEEE802.3ap 10 Gbps transmission standard.
- **Differential impedance data**
With a strict time of $T_r = 35ps$, its contact structure matches 100 Ohm $\pm 10\%$ differential impedance.

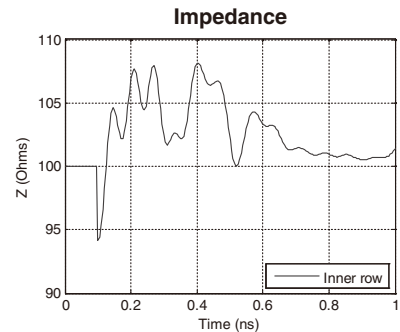
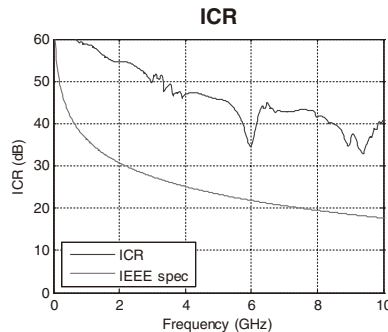

■ Mating variation diagram

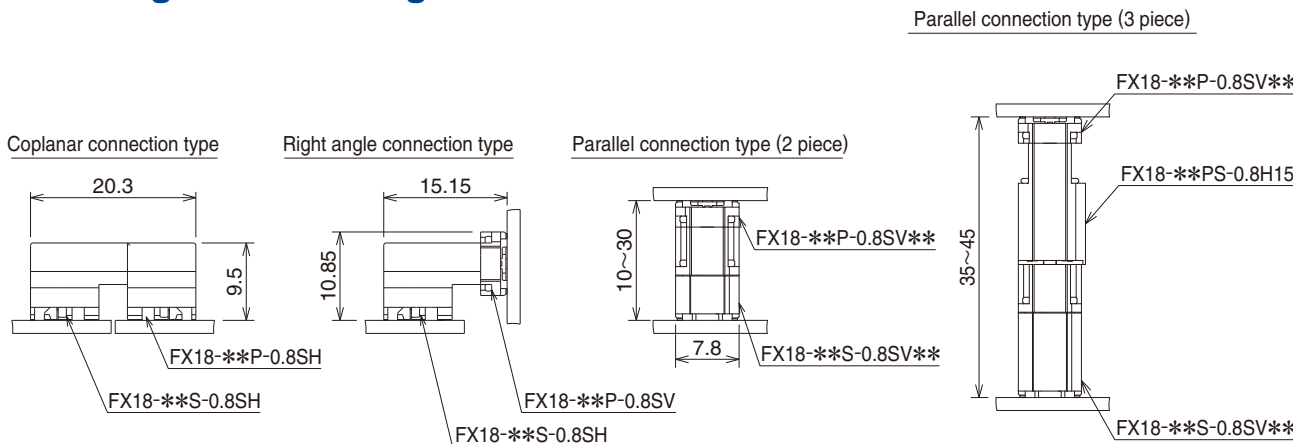

Product Specifications

Ratings	Rated Current	0.5 A (signal contacts) 3.0 A (MF contact) (Note 3)	Operating Temperature Range : -55~85°C (Note 1) Storage Temperature Range : -10~60°C (Note 2)
	Rated Voltage	AC100V	

Item	Specifications	Conditions
1. Contact Resistance	Maximum of 90 mΩ	Measured with 100 mA
2. Insulation Resistance	Minimum of 1,000 MΩ	Measured with DC 250 V
3. Withstanding Voltage	No flashover or breakdown	Electrification for 1 minutes at AC 300 V
4. Durability	Contact Resistance: Maximum of 100 mΩ	500 mating cycles
5. Vibration Resistance	No electrical discontinuity of 1 μ or greater	10 cycles each for the three axial directions (1 cycle = 5 minutes) at frequency 10-55 Hz, half amplitude 0.75 mm
6. Shock Resistance	No electrical discontinuity of 1 μ or greater	Acceleration: 490 m/s ² , Retention time: 11 ms, Semi-sinusoidal 3 axes both directions 3 times each.
7. Humidity Resistance	Contact Resistance: Maximum of 100 mΩ Insulation Resistance: Minimum of 1,000 MΩ	96 hours at temperature: 40°C and humidity: 90~95%
8. Temperature Cycles	Contact Resistance: Maximum of 100 mΩ Insulation Resistance: Minimum of 1,000 MΩ	Temperature -55 °C → 85°C Time 30 → 30 minutes 5 cycles

(Note 1) Includes the temperature rise of power lines

(Note 2) The term "storage" refers to the long-term storage condition of unused products before PCB mounting.

(Note 3) Rated current is per contact.

Materials

● Right angle receptacle/right angle header/straight header

Component	Materials	Color/Finish	Specifications
Insulator	Polyamide resin	Black	UL94V-0
Signal Contact	Phosphorous bronze	Contact part: Gold plating Mounting part: Gold plating	————
MF Contact	Phosphorous bronze	Contact part: Gold plating Mounting part: Pure tin plating	————

● Straight header 10 mm height /Straight receptacle 15 mm and 20 mm heights

Component	Materials	Color/Finish	Specifications
Insulator	Polyamide resin	Black	UL94V-0
Signal Contact	Phosphorous bronze	Contact part: Gold plating Mounting part: Gold plating	————
MF Contact	Copper alloy	Contact part: Gold plating Mounting part: Pure tin plating	————

● Straight receptacle 10 mm height

Component	Materials	Color/Finish	Specifications
Insulator	Polyamide resin	Black	UL94V-0
Signal Contact	Copper alloy	Contact part: Gold plating Mounting part: Gold plating	————
MF Contact	Copper alloy	Contact part: Gold plating Mounting part: Pure tin plating	————

● Interposer 15 mm height

Component	Materials	Color/Finish	Specifications
Insulator	Polyamide resin/PBT resin	Black	UL94V-0
Signal Contact	Copper alloy	Contact part: Gold plating	————
MF Contact	Copper alloy	Contact part: Gold plating	————

Product Number Structure

Refer to the charts below for determining specific part number characteristics.

Please select connectors listed in this catalog when placing orders and be sure to check the latest delivery specifications at the time of ordering the product.

● Right angle receptacle

FX18 - 60 S - 0.8 SH

① ② ③ ④ ⑤

● Straight receptacle

FX18 - 60 S - 0.8 SV 15

① ② ③ ④ ⑤ ⑥

● Right angle header

FX18 - 60 P - 0.8 SH

① ② ③ ④ ⑤

● Interposer

FX18 - 60 PS - 0.8 H 15

① ② ③ ④ ⑤ ⑥

● Straight header

FX18 - 60 P - 0.8 SV 10

① ② ③ ④ ⑤ ⑥

① Series Name	: FX18
② No. of Contacts	
③ Connector Type	S: Receptacle type P: Header type
④ Contact Pitch	: 0.8 mm
⑤ Product Shape	SH: Right angle type SV: Straight type H: Interposer type
⑥ Stacking Height	

FX18 Series Mating Diagram

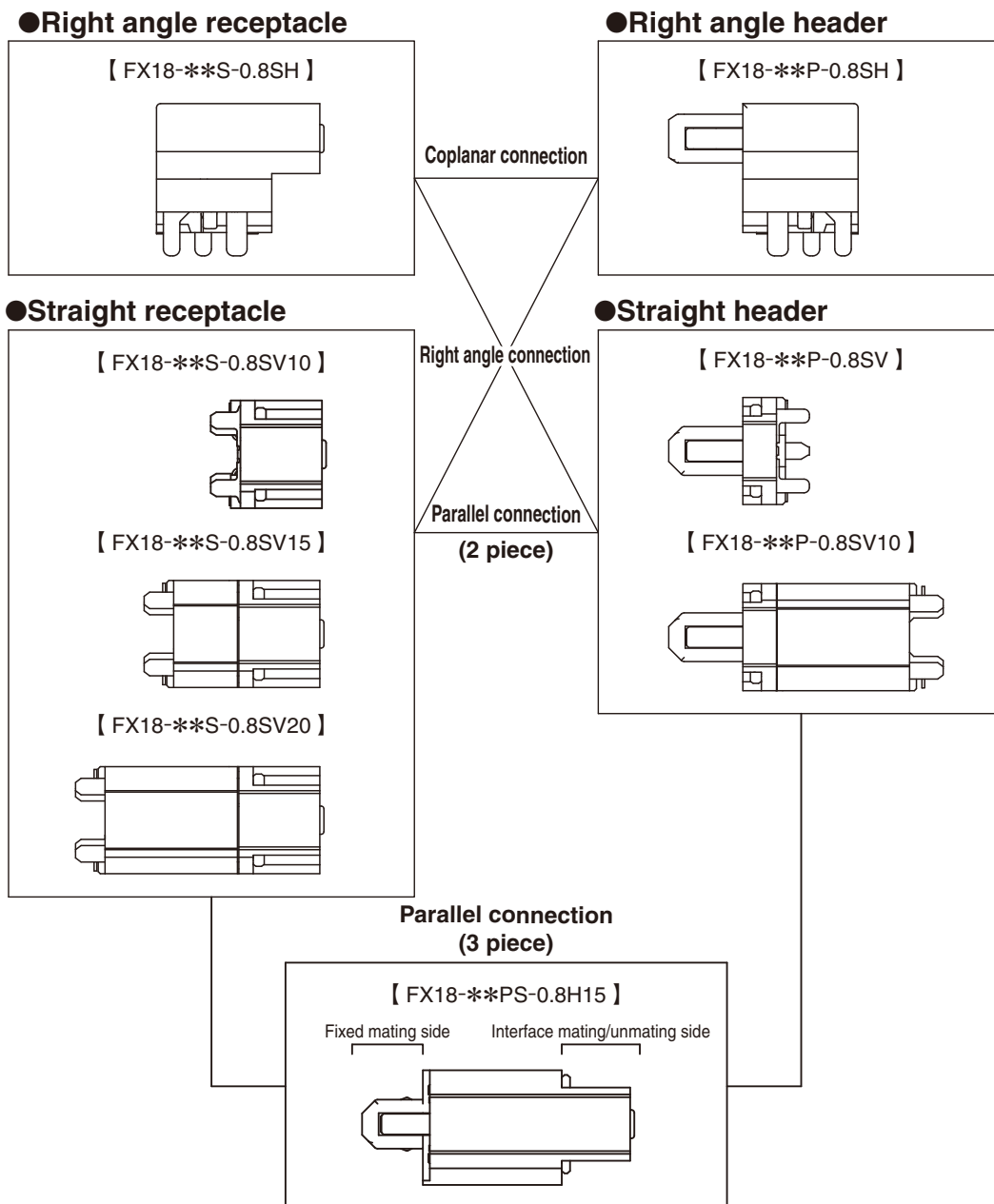

2 piece Parallel Connection Type

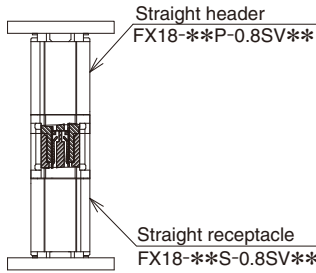

Stack height variation table (2 piece)

	FX18-**-P-0.8SV	FX18-**-P-0.8SV10
FX18-**-S-0.8SV10	10mm	20mm
FX18-**-S-0.8SV15	15mm	25mm
FX18-**-S-0.8SV20	20mm	30mm

3 piece parallel connection type

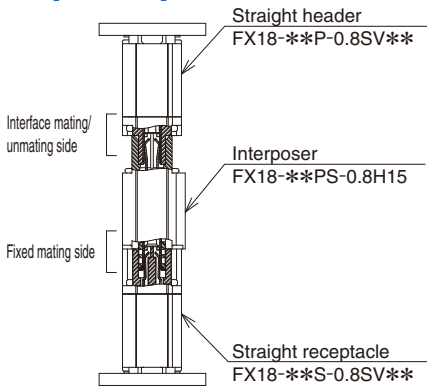

Stack height variation table (3 pieces)

	FX18-**-PS-0.8H15	
	FX18-**-P-0.8SV	FX18-**-P-0.8SV10
FX18-**-S-0.8SV10	25mm	35mm
FX18-**-S-0.8SV15	30mm	40mm
FX18-**-S-0.8SV20	35mm	45mm

SI Data

Contact assignment

We recommend the following contact configuration to match 100 ohm differential impedance and reduce crosstalk.

Contact assignment (40 pos.)

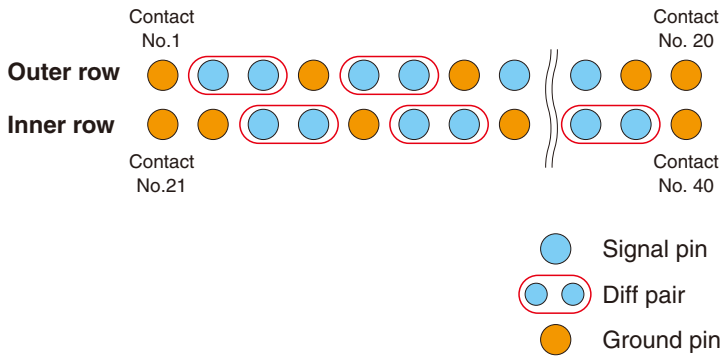

Coplanar connection type showing signal contact shape

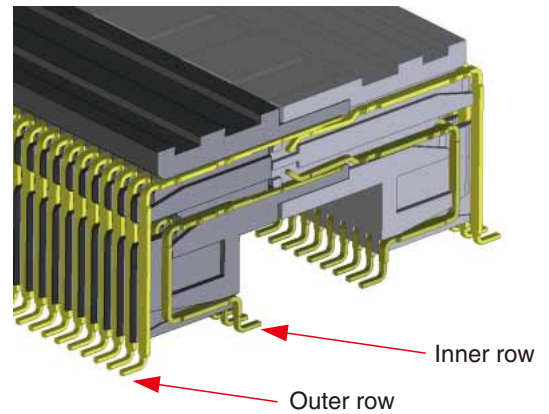

Impedance

Satisfies $100 \Omega \pm 10\%$ at $T_r = 35 \text{ ps}$

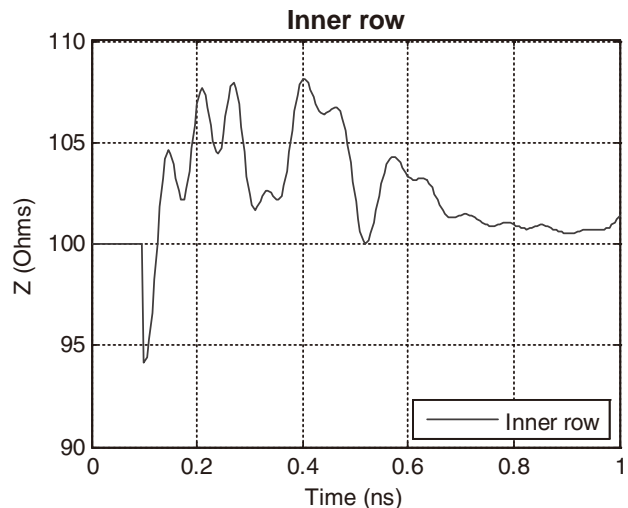
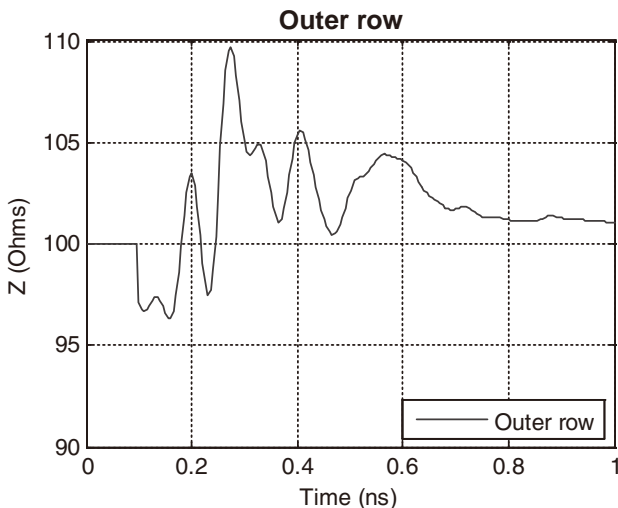

● Insertion loss

Maintains a good insertion loss of up to 10 GHz

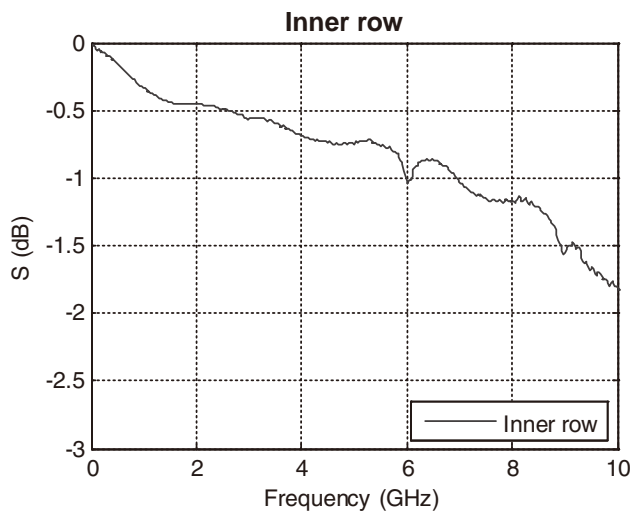
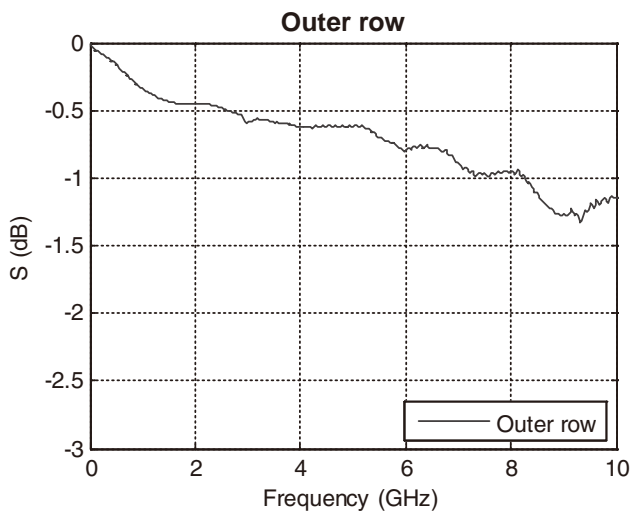

● Return loss

Enough margin to satisfy IEEE802.3ap 10 Gbps transmission protocol.

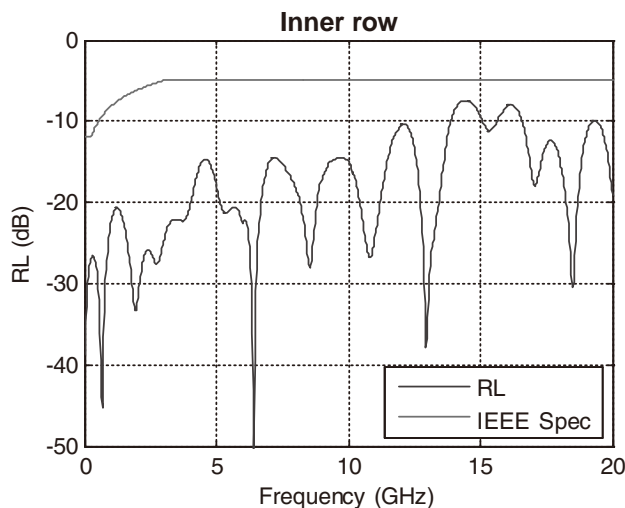
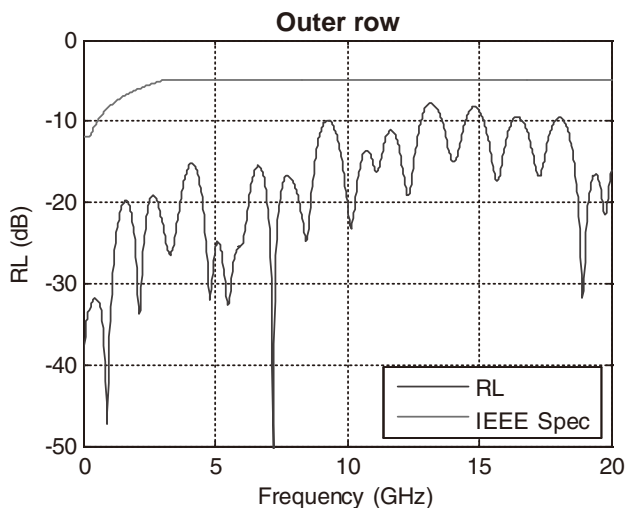

● NEXT

Lower crosstalk up to 10 GHz

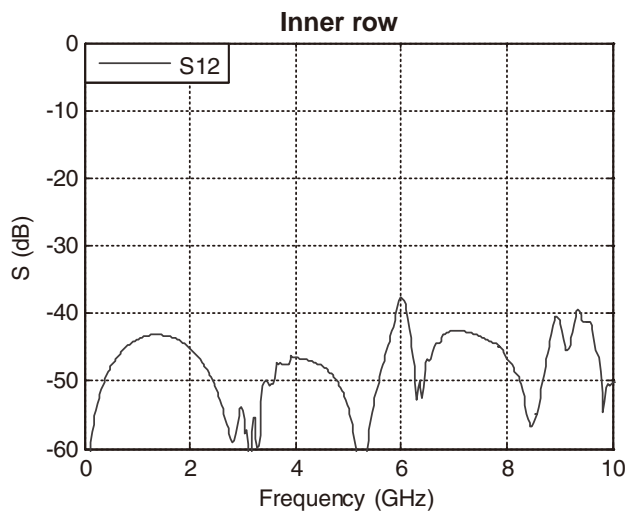
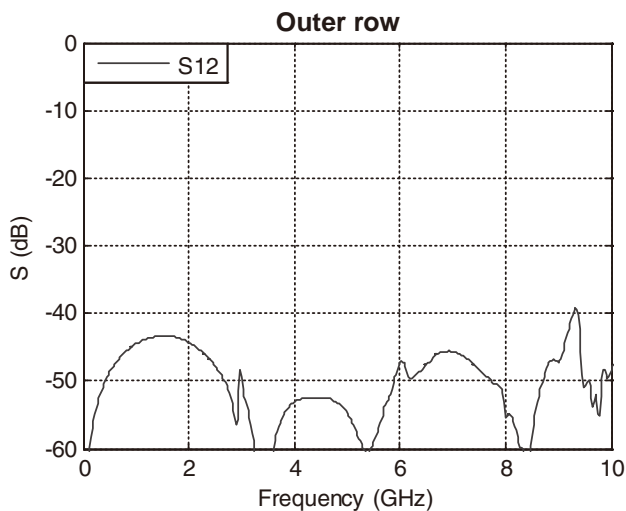

Contact assignment (40 pos.)

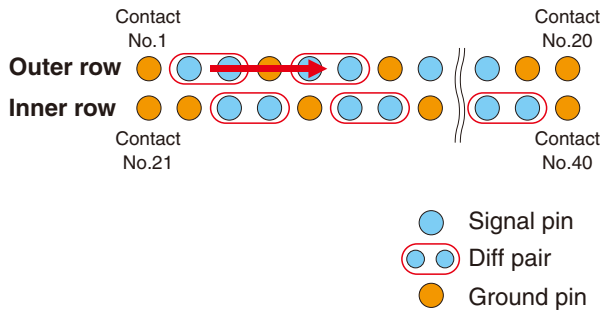

Fig 1.

Contact assignment (40 pos.)

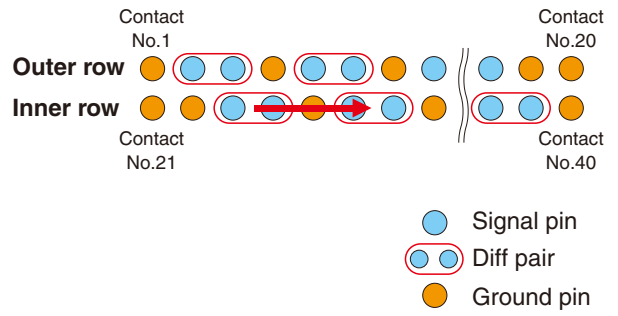
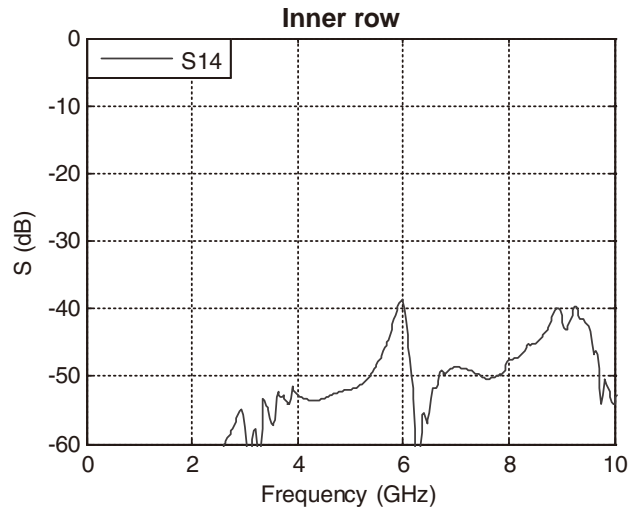
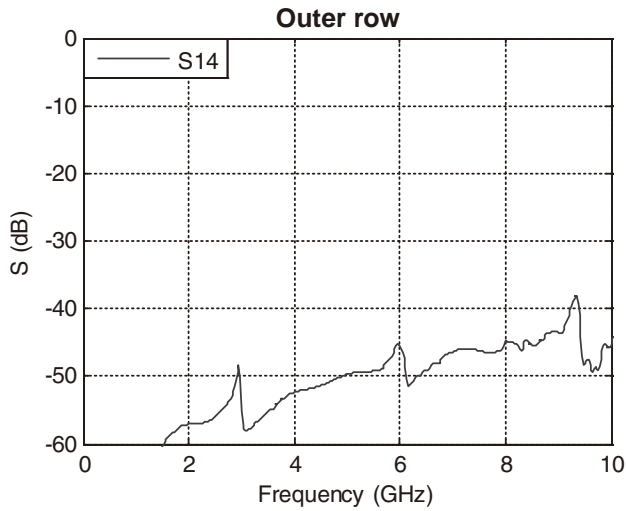

Fig 2.

FEXT

Lower crosstalk up to 10 GHz



ICR-FEXT

Enough margin to satisfy IEEE802.3ap 10 Gbps transmission protocol.

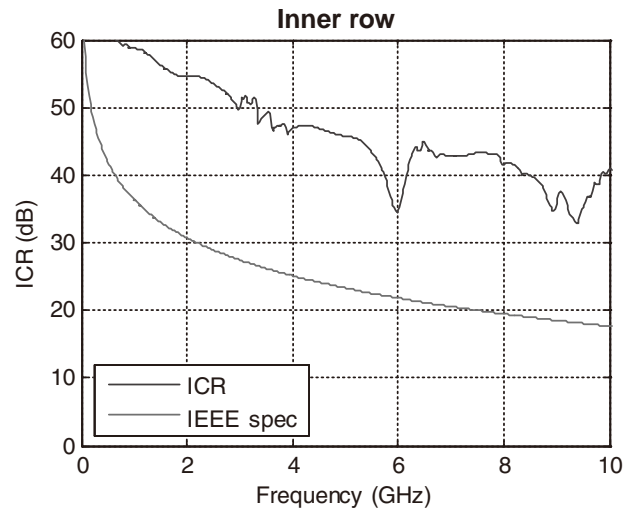
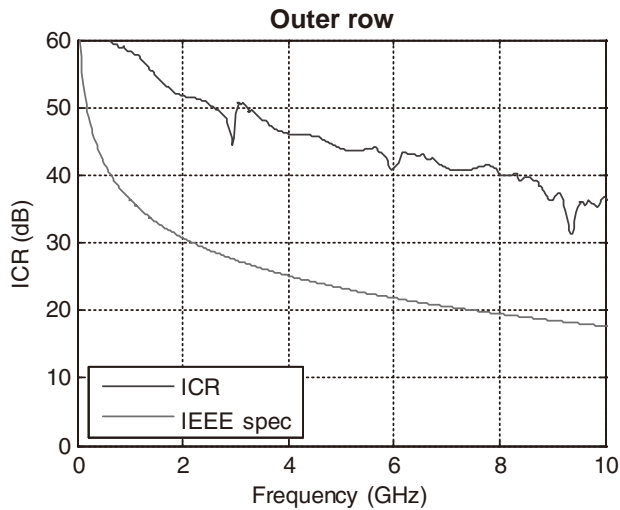

● Right angle receptacle

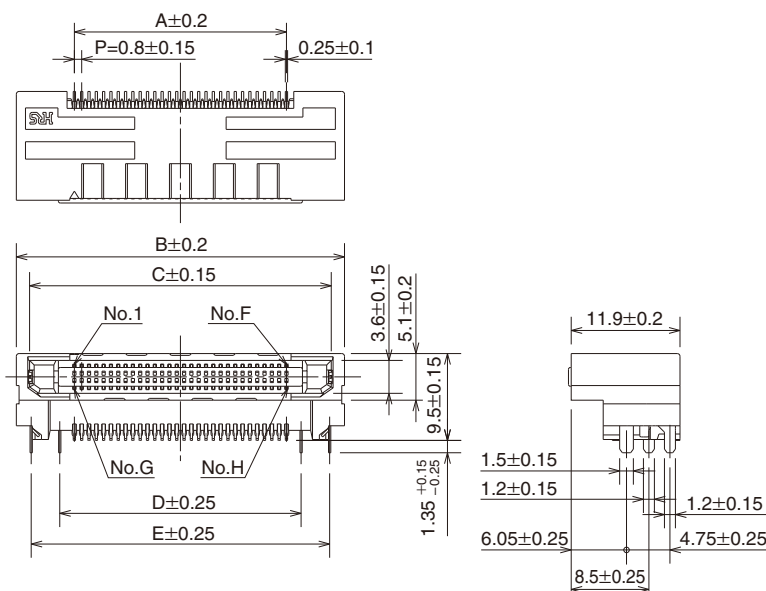

Unit: mm

Part No.	HRS No.	A	B	C	D	E	F	G	H (No. of contacts)
★ FX18-40S-0.8SH	CL579-0009-4	15.2	27.9	25.0	18.4	24.65	20	21	40
★ FX18-60S-0.8SH	CL579-0010-3	23.2	35.9	33.0	26.4	32.65	30	31	60
★ FX18-80S-0.8SH	CL579-0011-6	31.2	43.9	41.0	34.4	40.65	40	41	80
★ FX18-100S-0.8SH	CL579-0012-9	39.2	51.9	49.0	42.4	48.65	50	51	100
★ FX18-120S-0.8SH	CL579-0013-1	47.2	59.9	57.0	50.4	56.65	60	61	120
★ FX18-140S-0.8SH	CL579-0014-4	55.2	67.9	65.0	58.4	64.65	70	71	140

★Indicates products that are currently available. Other contact counts may be under development, contact your local rep for details

● Right angle header

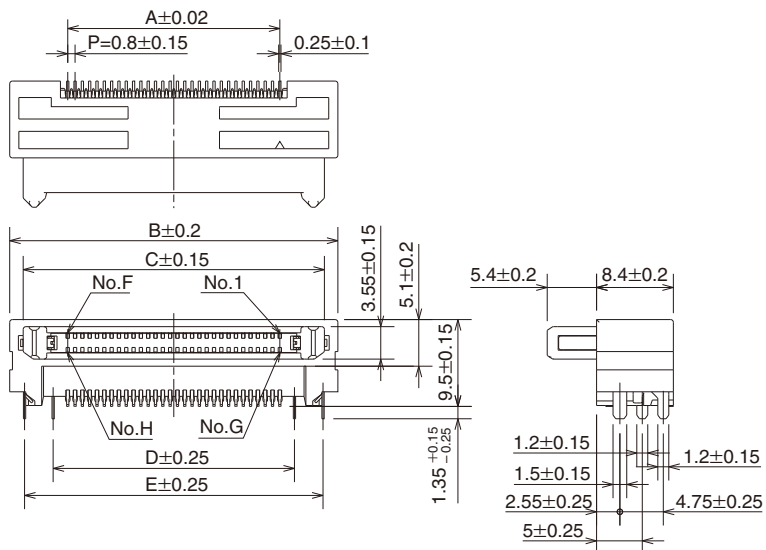

Unit: mm

Part No.	HRS No.	A	B	C	D	E	F	G	H (No. of contacts)
★ FX18-40P-0.8SH	CL579-0002-5	15.2	27.9	24.95	18.4	24.65	20	21	40
★ FX18-60P-0.8SH	CL579-0003-8	23.2	35.9	32.95	26.4	32.65	30	31	60
★ FX18-80P-0.8SH	CL579-0004-0	31.2	43.9	40.95	34.4	40.65	40	41	80
★ FX18-100P-0.8SH	CL579-0005-3	39.2	51.9	48.95	42.4	48.65	50	51	100
★ FX18-120P-0.8SH	CL579-0006-6	47.2	59.9	56.95	50.4	56.65	60	61	120
★ FX18-140P-0.8SH	CL579-0007-9	55.2	67.9	64.95	58.4	64.65	70	71	140

★Indicates products that are currently available. Other contact counts may be under development, contact your local rep for details

● Straight header

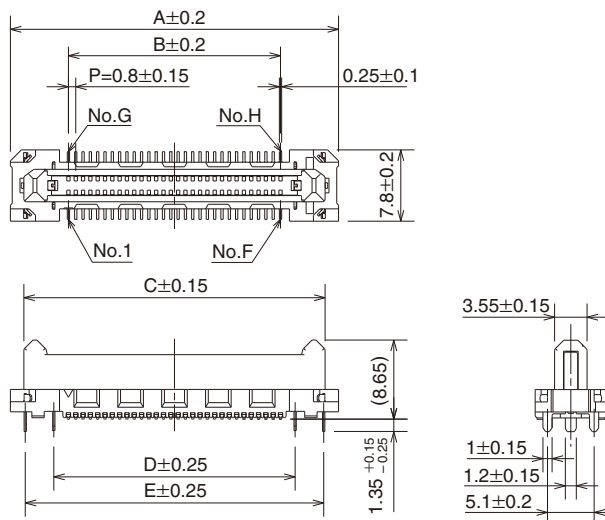

Unit: mm

Part No.	HRS No.	A	B	C	D	E	F	G	H (No of contacts)
★ FX18-40P-0.8SV	CL579-0016-0	27.9	15.2	24.95	18.4	24.65	20	21	40
★ FX18-60P-0.8SV	CL579-0017-2	35.9	23.2	32.95	26.4	32.65	30	31	60
★ FX18-80P-0.8SV	CL579-0018-5	43.9	31.2	40.95	34.4	40.65	40	41	80
★ FX18-100P-0.8SV	CL579-0019-8	51.9	39.2	48.95	42.4	48.65	50	51	100
★ FX18-120P-0.8SV	CL579-0020-7	59.9	47.2	56.95	50.4	56.65	60	61	120
★ FX18-140P-0.8SV	CL579-0021-0	67.9	55.2	64.95	58.4	64.65	70	71	140

★Indicates products that are currently available. Other contact counts may be under development, contact your local rep for details

● Straight header (10 mm stack height)

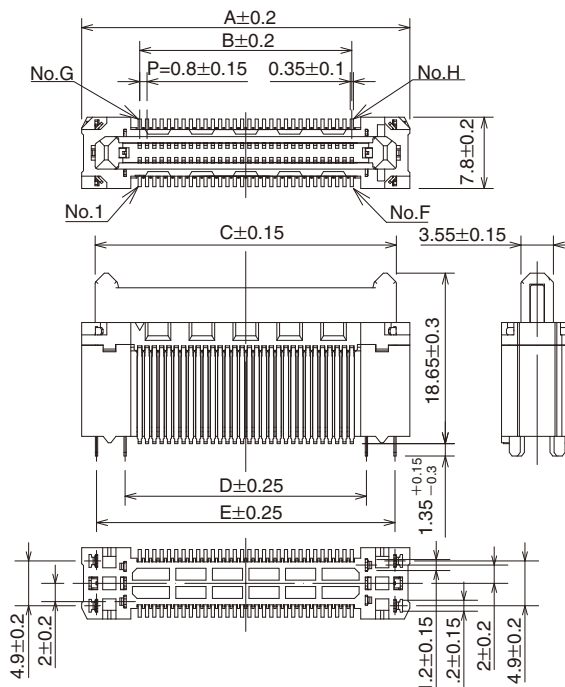

Unit: mm

Part No.	HRS No.	A	B	C	D	E	F	G	H (No of contacts)
★ FX18-40P-0.8SV10	CL579-0022-2	27.9	15.2	24.95	18.4	24.65	20	21	40
★ FX18-60P-0.8SV10	CL579-0023-5	35.9	23.2	32.95	26.4	32.65	30	31	60
★ FX18-80P-0.8SV10	CL579-0024-8	43.9	31.2	40.95	34.4	40.65	40	41	80
★ FX18-100P-0.8SV10	CL579-0034-1	51.9	39.2	48.95	42.4	48.65	50	51	100
★ FX18-120P-0.8SV10	CL579-0025-0	59.9	47.2	56.95	50.4	56.65	60	61	120
★ FX18-140P-0.8SV10	CL579-0035-4	67.9	55.2	64.95	58.4	64.65	70	71	140

★Indicates products that are currently available. Other contact counts may be under development, contact your local rep for details

● Straight receptacle (10 mm stack height)

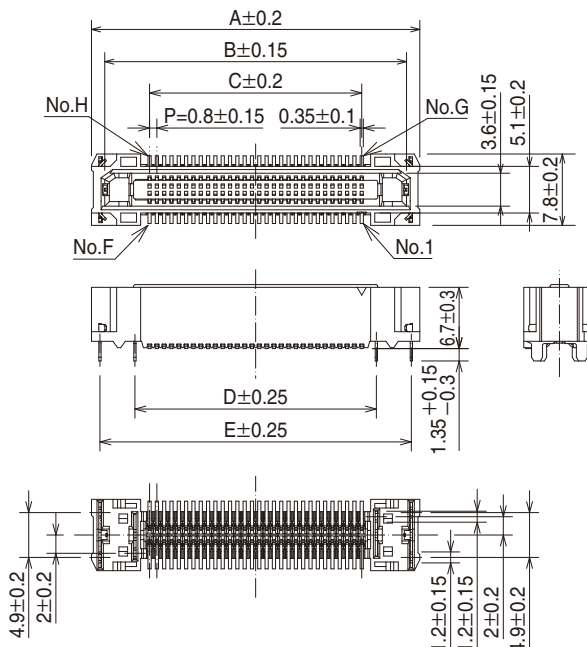

Unit: mm

Part No.	HRS No.	A	B	C	D	E	F	G	H (No. of contacts)
FX18-40S-0.8SV10	—	27.9	25	15.2	18.4	26.05	20	21	40
FX18-60S-0.8SV10	—	35.9	33	23.2	26.4	34.05	30	31	60
FX18-80S-0.8SV10	—	43.9	41	31.2	34.4	42.05	40	41	80
FX18-100S-0.8SV10	—	51.9	49	39.2	42.4	50.05	50	51	100
FX18-120S-0.8SV10	—	59.9	57	47.2	50.4	58.05	60	61	120
★ FX18-140S-0.8SV10	CL579-0060-1	67.9	65	55.2	58.4	66.05	70	71	140

★Indicates products that are currently available. Other contact counts may be under development, contact your local rep for details

● Straight receptacle (15 mm stack height)

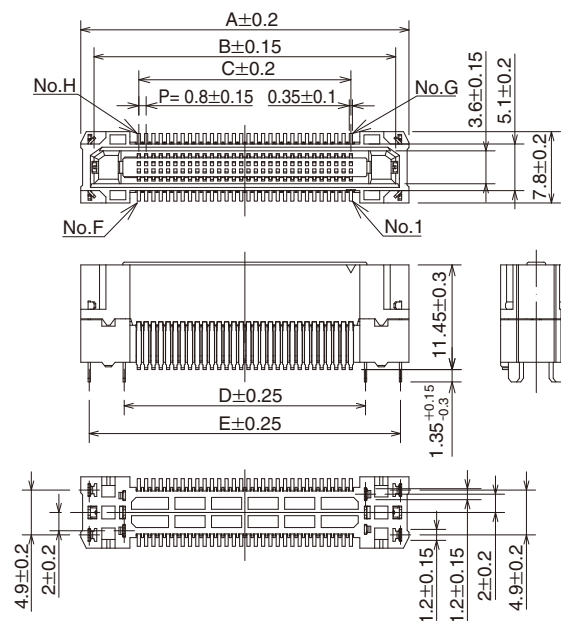
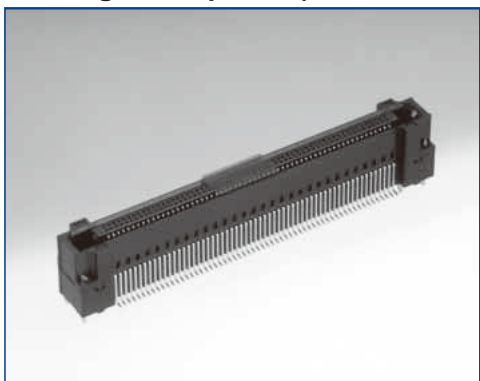

Unit: mm

Part No.	HRS No.	A	B	C	D	E	F	G	H (No. of contacts)
★ FX18-40S-0.8SV15	CL579-0026-3	27.9	25	15.2	18.4	26.05	20	21	40
★ FX18-60S-0.8SV15	CL579-0027-6	35.9	33	23.2	26.4	34.05	30	31	60
★ FX18-80S-0.8SV15	CL579-0028-9	43.9	41	31.2	34.4	42.05	40	41	80
★ FX18-100S-0.8SV15	CL579-0036-7	51.9	49	39.2	42.4	50.05	50	51	100
★ FX18-120S-0.8SV15	CL579-0029-1	59.9	57	47.2	50.4	58.05	60	61	120
★ FX18-140S-0.8SV15	CL579-0037-0	67.9	65	55.2	58.4	66.05	70	71	140

★Indicates products that are currently available. Other contact counts may be under development, contact your local rep for details

● Straight receptacle (20 mm stack height)

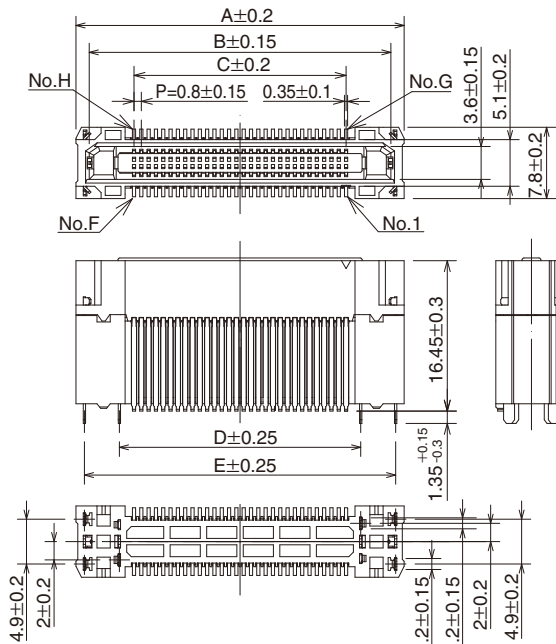
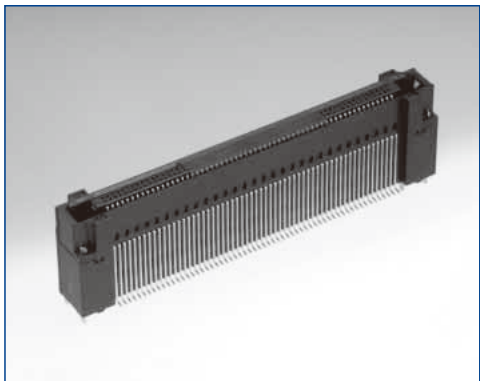

Unit: mm

Part No.	HRS No.	A	B	C	D	E	F	G	H (No. of contacts)
★ FX18-40S-0.8SV20	CL579-0030-0	27.9	25	15.2	18.4	26.05	20	21	40
★ FX18-60S-0.8SV20	CL579-0031-3	35.9	33	23.2	26.4	34.05	30	31	60
★ FX18-80S-0.8SV20	CL579-0032-6	43.9	41	31.2	34.4	42.05	40	41	80
★ FX18-100S-0.8SV20	CL579-0038-2	51.9	49	39.2	42.4	50.05	50	51	100
★ FX18-120S-0.8SV20	CL579-0033-9	59.9	57	47.2	50.4	58.05	60	61	120
★ FX18-140S-0.8SV20	CL579-0039-5	67.9	65	55.2	58.4	66.05	70	71	140

★ Indicates products that are currently available. Other contact counts may be under development, contact your local rep for details

● Interposer (15 mm height)

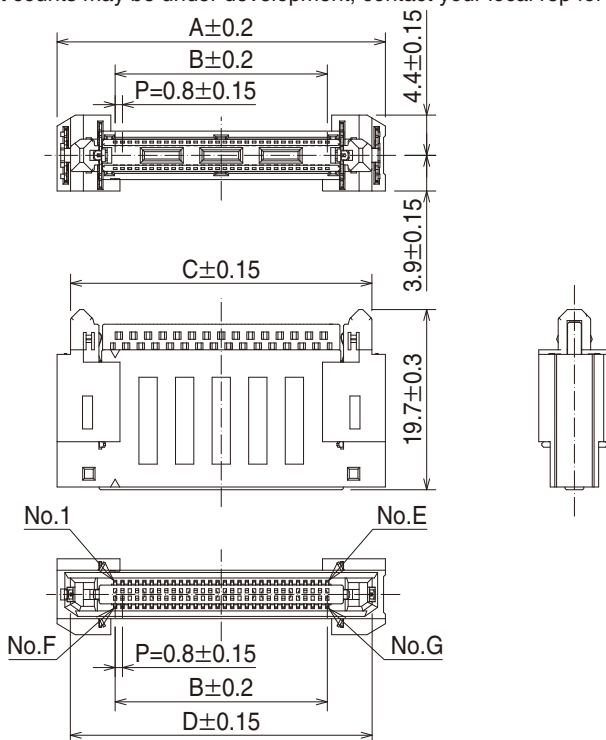

Unit: mm

Part No.	HRS No.	A	B	C	D	E	F	G (No. of contacts)
FX18-40PS-0.8H15	—	27.9	15.2	24.95	25	20	21	40
FX18-60PS-0.8H15	—	35.9	23.2	32.95	33	30	31	60
FX18-80PS-0.8H15	—	43.9	31.2	40.95	41	40	41	80
FX18-100PS-0.8H15	—	51.9	39.2	48.95	49	50	51	100
FX18-120PS-0.8H15	—	59.9	47.2	56.95	57	60	61	120
★ FX18-140PS-0.8H15	CL579-0054-9	67.9	55.2	64.95	65	70	71	140

★ Indicates products that are currently available. Other contact counts may be under development, contact your local rep for details

Recommended Land Pattern Dimensions

(PCB thickness: t = 1.6 mm/Metal mask thickness: t = 0.12 mm)

Right angle receptacle/right angle header

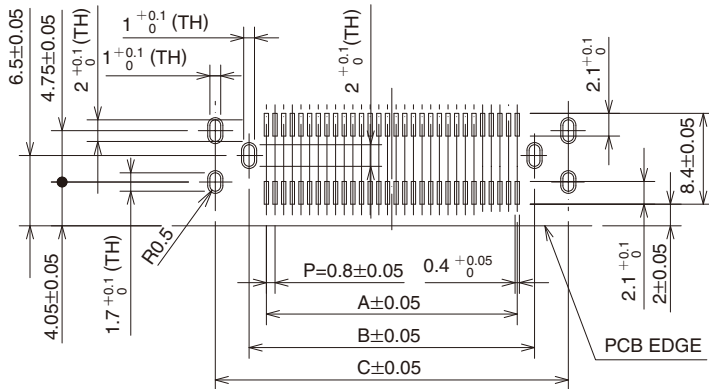

Part No.	A	B	C
FX18-40S-0.8SH	15.2	18.4	24.65
FX18-40P-0.8SH			
FX18-60S-0.8SH	23.2	26.4	32.65
FX18-60P-0.8SH			
FX18-80S-0.8SH	31.2	34.4	40.65
FX18-80P-0.8SH			
FX18-100S-0.8SH	39.2	42.4	48.65
FX18-100P-0.8SH			
FX18-120S-0.8SH	47.2	50.4	56.65
FX18-120P-0.8SH			
FX18-140S-0.8SH	55.2	58.4	64.65
FX18-140P-0.8SH			

Straight header

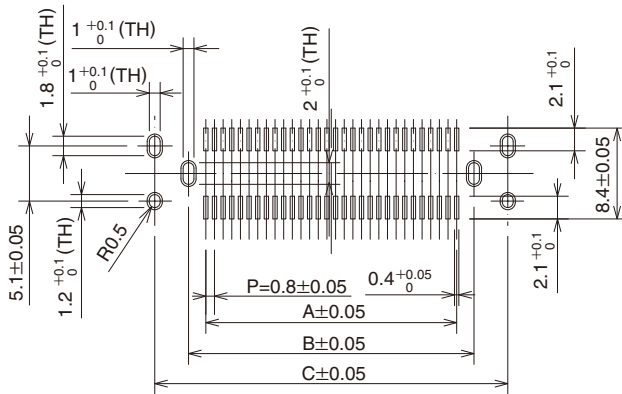

Part No.	A	B	C
FX18-40P-0.8SV	15.2	18.4	24.65
FX18-60P-0.8SV	23.2	26.4	32.65
FX18-80P-0.8SV	31.2	34.4	40.65
FX18-100P-0.8SV	39.2	42.4	48.65
FX18-120P-0.8SV	47.2	50.4	56.65
FX18-140P-0.8SV	55.2	58.4	64.65

Straight header (SV 10 mm height)

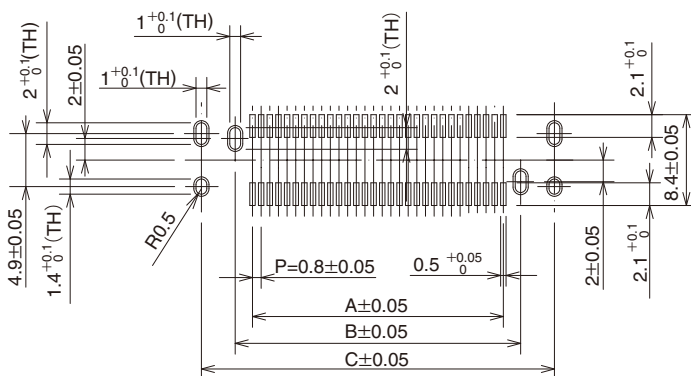

Part No.	A	B	C
FX18-40P-0.8SV10	15.2	18.4	24.65
FX18-60P-0.8SV10	23.2	26.4	32.65
FX18-80P-0.8SV10	31.2	34.4	40.65
FX18-100P-0.8SV10	39.2	42.4	48.65
FX18-120P-0.8SV10	47.2	50.4	56.65
FX18-140P-0.8SV10	55.2	58.4	64.65

Straight receptacle (SV10/SV15/SV20 mm heights)

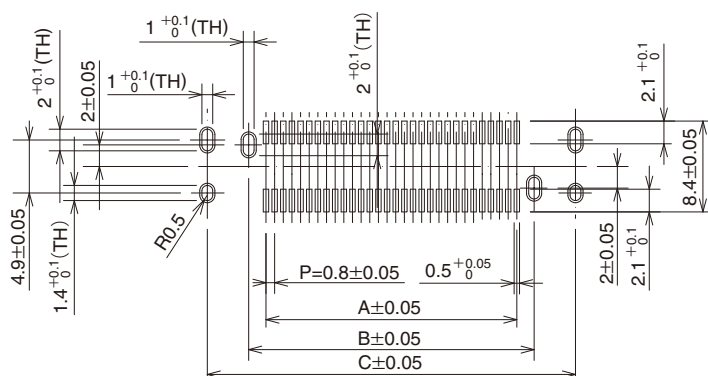

Part No.	A	B	C
FX18-40S-0.8SV10/15/20	15.2	18.4	26.05
FX18-60S-0.8SV10/15/20	23.2	26.4	34.05
FX18-80S-0.8SV10/15/20	31.2	34.4	42.05
FX18-100S-0.8SV10/15/20	39.2	42.4	50.05
FX18-120S-0.8SV10/15/20	47.2	50.4	58.05
FX18-140S-0.8SV10/15/20	55.2	58.4	66.05

◆ Packaging tray (dimensions and quantities)

● Right angle receptacle/right angle header

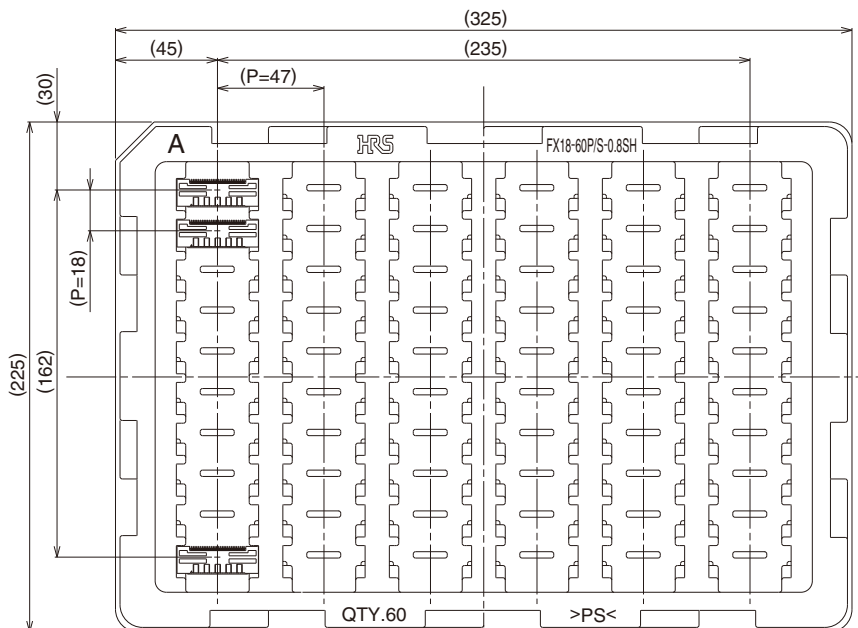

Part No.	Quantity
FX18-40S-0.8SH	70
FX18-40P-0.8SH	
FX18-60S-0.8SH	60
FX18-60P-0.8SH	
FX18-80S-0.8SH	50
FX18-80P-0.8SH	
FX18-100S-0.8SH	40
FX18-100P-0.8SH	
FX18-120S-0.8SH	40
FX18-120P-0.8SH	
FX18-140S-0.8SH	40
FX18-140P-0.8SH	

● Straight header/Straight receptacle for 10 mm stack height

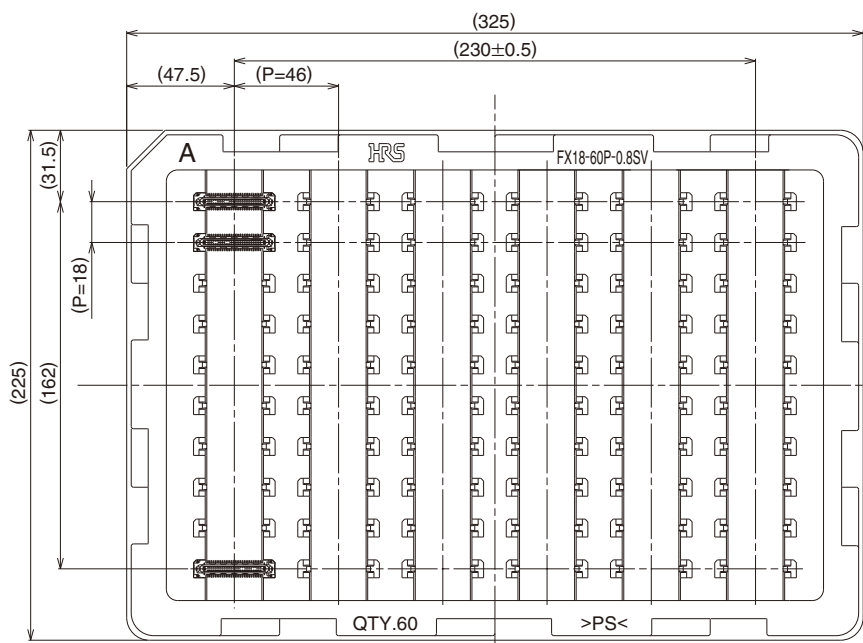

Part No.	Quantity
FX18-40P-0.8SV	70
FX18-40S-0.8SV10	
FX18-60P-0.8SV	60
FX18-60S-0.8SV10	
FX18-80P-0.8SV	50
FX18-80S-0.8SV10	
FX18-100P-0.8SV	40
FX18-100S-0.8SV10	
FX18-120P-0.8SV	40
FX18-120S-0.8SV10	
FX18-140P-0.8SV	40
FX18-140S-0.8SV10	

● Straight header 10 mm / Straight receptacle 15 mm / Straight receptacle 20 mm

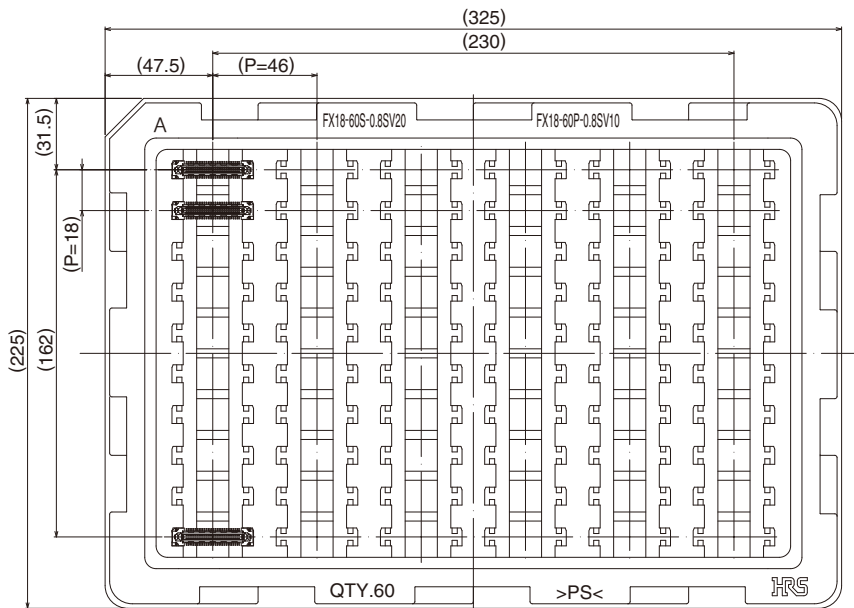

Part No.	Quantity
FX18-40P-0.8SV10	60
FX18-40S-0.8SV15	
FX18-40S-0.8SV20	
FX18-60P-0.8SV10	60
FX18-60S-0.8SV15	
FX18-60S-0.8SV20	
FX18-80P-0.8SV10	50
FX18-80S-0.8SV15	
FX18-80S-0.8SV20	
FX18-100P-0.8SV10	40
FX18-100S-0.8SV20	
FX18-120P-0.8SV10	40
FX18-120S-0.8SV15	
FX18-120S-0.8SV20	
FX18-140P-0.8SV10	30
FX18-140S-0.8SV15	
FX18-140S-0.8SV20	

● Interposer 15 mm height

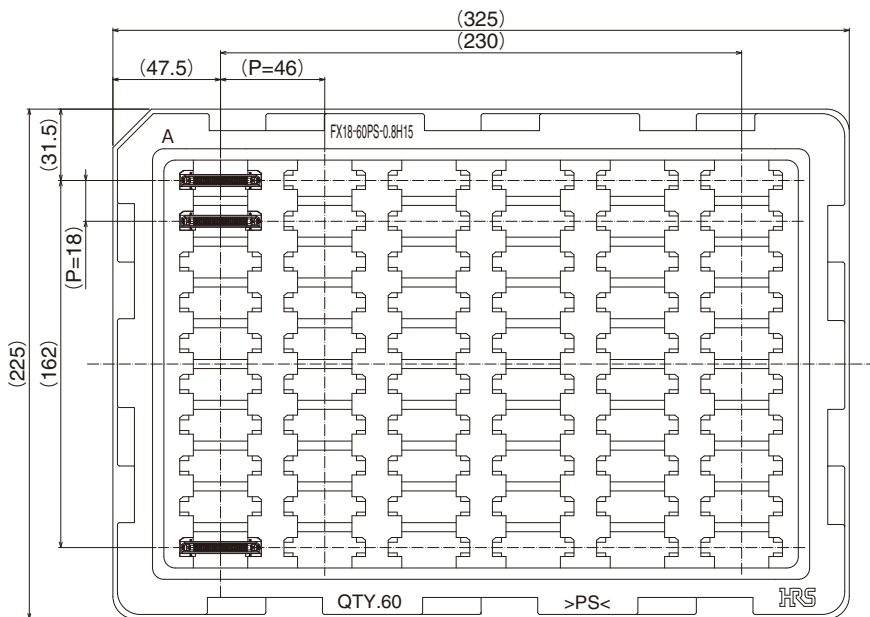

Part No.	Quantity
FX18-40PS-0.8H15	60
FX18-60PS-0.8H15	60
FX18-80PS-0.8H15	50
FX18-100PS-0.8H15	40
FX18-120PS-0.8H15	40
FX18-140PS-0.8H15	30

Temperature Profile

This temperature profile was tested under the following conditions, and any attempt to recreate will vary depending on the external conditions.

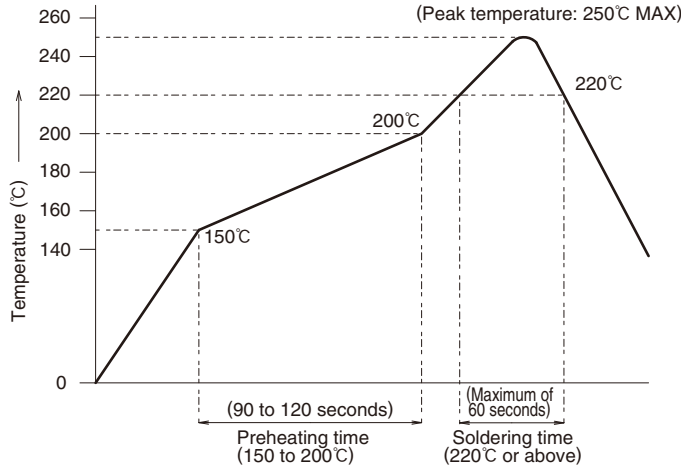

(Applicable Conditions)

Test PCB Size Dimensions : 110 × 50 × 1.6 (mm)
 Material : Glass epoxy
 Solder composition : Sn- 3 Ag- 0.5 Cu
 Flux contained quantity : 11 wt%
 Metal mask thickness : 0.12 mm

(Note 1) This temperature profile contains recommended values and is for reference only.
 (Note 2) Reflow process should not exceed 2 times.
 (Note 3) Cream solder type: Will differ due to the amount used and manufacturer

Washing conditions

Washing with organic solvent

Solvent	Washing in normal temperature	Washing in heated condition
IPA (Isopropyl alcohol)	○	○

Water based cleaning

When using water based cleaning agents (including terpene, and alkali saponifiers), pay special attention to how the cleaning agent will react to specific metals and plastics before selecting one of them. Various cleaning agent manufacturers publish reaction tables for their cleaning agents. Do not leave connectors with moisture remaining on them.

Cautions when washing

The electrical performance may deteriorate if the flux or cleaning detergent is left on the connector after the cleaning. Check thoroughly to ensure that there is no residue left on any of the surfaces.

Operating Precautions

Mating gap permitted

The effective mating length of the MF contact A is 2.5 mm, signal contact is 2 mm and MF contact B is 1.5 mm. The approved amount of gap between the header and receptacle should not exceed 1 mm.

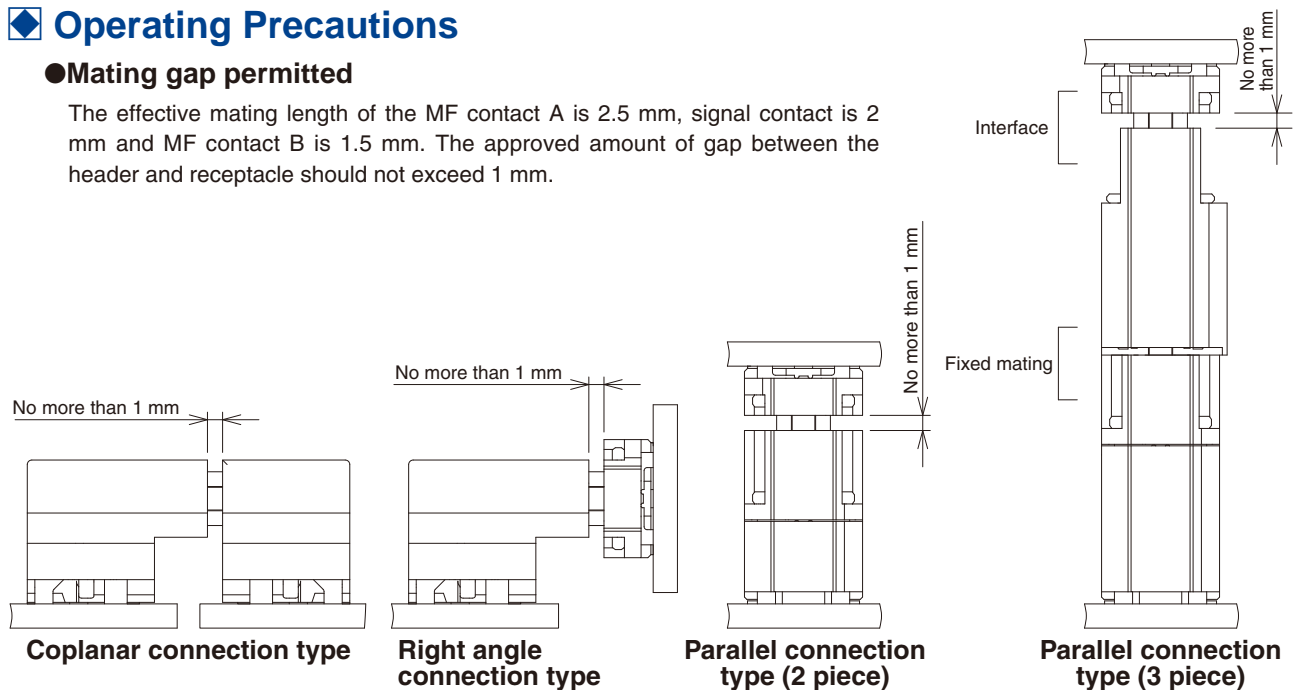

- Provide another form of support to the PCB, this connector was not designed to be the main form of support.
- Do not mate the connectors at an angle, refer to the rotation mating/unmating guideline (TADC 4-210630). (For the guideline, please contact the sales representative of our company.)
- When using the 15 mm height interposer, be cautious of the items listed below.
 - 1) The lock on the fixed mating side of the interposer is not designed to be the mate/unmate point. This section should not be mated/unmated more than 5 times.
 - 2) When mating these connectors, make sure to mate the fixed mating side first then mate the interface mating/unmating side to the header.
 - 3) The effective mating length of the MF contact A is 2.5 mm, signal contact is 2 mm and MF contact B is 1.5 mm.
 - 4) The approved amount of gap between the header and receptacle should not exceed 1 mm.

MEMO :

Lined area for notes, consisting of horizontal dashed lines.

USA:

HIROSE ELECTRIC (U.S.A.), INC. Headquarters
 2688 Westhills Court, Simi Valley, CA 93065-6235
 Phone : +1-805-522-7958
 Fax : +1-805-522-3217
<http://www.hiroseusa.com>

USA:

HIROSE ELECTRIC (U.S.A.), INC. San Jose Office
 3255 Scott Boulevard, Building 7, Suite 101
 Santa Clara, CA 95054
 Phone : +1-408-253-9640
 Fax : +1-408-253-9641
<http://www.hiroseusa.com>

USA:

HIROSE ELECTRIC (U.S.A.), INC. Detroit Office (Automotive)
 37677 Professional Center Drive, Suite #100C
 Livonia, MI 48154
 Phone : +1-734-542-9963
 Fax : +1-734-542-9964
<http://www.hiroseusa.com>

THE NETHERLANDS:

HIROSE ELECTRIC EUROPE B.V.
 Hogehillweg #8 1101 CC Amsterdam Z-O
 Phone : +31-20-6557460
 Fax : +31-20-6557469
<http://www.hiroseeurope.com>

GERMANY:

HIROSE ELECTRIC EUROPE B.V. German Branch
 Herzog-Carl-Strasse 4 D-73760 Ostfildern
 (Scharnhauser Park)
 Phone : +49-711-4560-02-1
 Fax : +49-711-4560-02-299
<http://www.hirose.de>

UNITED KINGDOM:

HIROSE ELECTRIC EUROPE B.V. UK Branch
 22 Vincent Avenue, Crownhill Business
 Centre, Crownhill, Milton Keynes, MK8 0AB
 Phone : +44-1908-305750
 Fax : +44-1908-305768
<http://www.hirose.co.uk>

CHINA:

HIROSE ELECTRIC TRADING (SHANGHAI) CO., LTD.
 1601, Henderson Metropolitan, NO.300, East Nanjing
 Road, Huangpu District, Shanghai, China 200001
 Phone : +86-21-6391-3355
 Fax : +86-21-6391-3335
<http://www.hirose-china.com.cn>

CHINA:

HIROSE ELECTRIC TRADING (SHANGHAI) CO., LTD. Beijing Branch
 A1001, Ocean International Center, Building 56# East 4th
 Ring Middle Road, Chao Yang District, Beijing, 100025
 Phone : +86-10-5165-9332
 Fax : +86-10-5908-1381
<http://www.hirose-china.com.cn>

CHINA:

HIROSE ELECTRIC TECHNOLOGIES (SHENZHEN) CO., LTD.
 Room 09-13, 19/F, Office Tower Shun Hing Square, Di Wang Commercial Centre
 5002, ShenNanDong Road, ShenZhen City, Guangdong Province, 518008
 Phone : +86-755-8207-0851
 Fax : +86-755-8207-0873
<http://www.hirose-china.com.cn>

HONG KONG:

HIROSE ELECTRIC HONGKONG TRADING CO., LTD.
 Room 1001, West Wing, Tsim Sha Tsui Centre, 66
 Mody Road, Tsim Sha Tsui East, Kowloon, Hong Kong
 Phone : +852-2803-5338
 Fax : +852-2591-6560
<http://www.hirose-hongkong.com.hk>

TAIWAN:

HIROSE ELECTRIC TAIWAN CO., LTD.
 103 8F, No.87, Zhengzhou Rd., Taipei
 Phone : +886-2-2555-7377
 Fax : +886-2-2555-7350
<http://www.hirose-taiwan.com.tw>

KOREA:

HIROSE KOREA CO., LTD.
 1261-10, Jeoungwhang-Dong, Shihung-City,
 Kyunggi-Do 429-450
 Phone : +82-31-496-7000, 7124
 Fax : +82-31-496-7100
<http://www.hirose.co.kr>

SINGAPORE:

HIROSE ELECTRIC SINGAPORE PTE. LTD.
 10 Anson Road #26-1 International Plaza
 079903
 Phone : +65-6324-6113
 Fax : +65-6324-6123
<http://www.hirose-singapore.com.sg>

INDIA:

HIROSE ELECTRIC SINGAPORE PTE. LTD. Bangalore Liaison office
 Unit No.03, Ground Floor, Explorer Building International Tech
 Park Whitefield Road, Bangalore 560066 Karnataka, India
 Phone : +65-6324-6113
 Fax : +65-6324-6123
<http://www.hirose-singapore.com.sg>

INDIA:

HIROSE ELECTRIC SINGAPORE PTE. LTD Delhi Liaison Office
 Suite No. 606 5th Floor SB Tower 1A/1 Sector
 16 A Filmcity Noida 201301 Uttar Pradesh-India
 Phone : +91-120-4804917
 Fax : +91-120-4804949
<http://www.hirose.com/sg/>

MALAYSIA:

HIROSE ELECTRIC SINGAPORE PTE. LTD (Representative office)
 1-10-07, Suntech @ Penang Cybercity (1164), Lintang
 Mayang Pasir 3, 11950, Bayan Baru, Penang, Malaysia.
 Phone : +604-619-2564
 Fax : +604-619-2574
<http://www.hirose.com/sg/>



HIROSE ELECTRIC CO., LTD.

6-3, Nakagawa Chuoh-2-Chome, Tsuzuki-Ku, Yokohama-Shi 224-8540, JAPAN
 TEL: +81-45-620-3526 Fax: +81-45-591-3726
<http://www.hirose.com>
<http://www.hirose-connectors.com>